



World Sailing Offshore Special Regulations

Extract for **Category 3 Multihulls**

JANUARY 2024 – DECEMBER 2025

© ORC Ltd. 2002, amendments 2003-2024 © World Sailing Limited

Version 1.13 – 16 February 2024

With Sail Canada Prescriptions



Copyright

When reprinting these regulations Member National Authorities and Organizing Authorities should:

- When reprinting these regulations Member National Authorities and Organizing Authorities should:
- request copyright permission from World Sailing and ORC Ltd (normally given free of charge),
- display a copyright acknowledgement with the reprint (similar to © ORC Ltd. 2002, amendments 2003-2024 © World Sailing Limited),
- make any amendments by deleting contrary provisions,
- indicate that changes have been made, and
- supply a copy of the reprint to each of World Sailing and ORC Ltd.

Official interpretations shall take precedence over these Special Regulations and will be indexed, numbered, dated and displayed on the World Sailing website:

<https://www.sailing.org/inside-world-sailing/rules-regulations/offshore-special-regulations/>

Language & Abbreviations Used

Mo – Monohulls

Mu – Multihulls

** – means the item applies to all types of boat in all Categories except 5 for which see Appendix B or 6 for which see Appendix C.

Green Type indicate Swiftsure Organizing Authority prescriptions.

Administration

The Offshore Special Regulation are administered by the World Sailing Special Regulation Sub-Committee whose terms of reference (available at: <https://www.sailing.org/inside-world-sailing/rules-regulations/constitution-regulations/>) are as follows:

World Sailing Regulation 6.9.8.3 - The Special Regulations Sub-Committee shall:

- (a) be responsible for the maintenance, revision and changes to the World Sailing Offshore Special Regulations governing offshore racing, under licence from ORC Ltd. Such changes shall be biennial with revised editions published in January of each even year, except that matters of an urgent nature affecting safety may be dealt with by changes to the Regulations on a shorter time scale.

- (b) monitor developments in offshore racing relative to the standards of safety and seaworthiness. Any queries please email: technical@sailing.org

For any queries regarding Sail Canada prescriptions please email: offshore@sailing.ca

SECTION 1 – FUNDAMENTAL AND DEFINITIONS

Categories

- ** 1.01 **Purpose and Use**
- ** 1.01.1 The purpose of the Offshore Special Regulations (OSR) is to establish uniform minimum equipment, accommodation and training standards for **monohull** and **multihull** (excluding proa [asymmetrical catamaran]) boats racing offshore.
- ** 1.01.2 The OSR do not replace, but supplement, the requirements of governmental authority, Classification Society certification, the Racing Rules of Sailing (RRS), Equipment Rules of Sailing (ERS), class rules and rating systems.
- ** 1.01.3 Use of the OSR does not guarantee total safety of the boat and her crew. Particular attention is drawn to the description of OSR for inshore racing which includes that adequate shelter and or effective rescue is available all along the course. This is not included in more onerous OSR categories.
- ** 1.02 **Responsibility of Person in Charge**
- ** 1.02.1 **Under RRS 3 the responsibility for a boat’s decision to participate in a race or continue racing is hers alone. The safety of a boat and her crew is the sole and inescapable responsibility of the *person in charge* who shall do his best to ensure that the boat is fully found, thoroughly seaworthy and manned by an experienced and appropriately trained crew who are physically fit to face all weather. The *person in charge* shall also assign a person to take over his responsibilities in the event of his incapacitation.**
- ** 1.02.2 Neither the establishment of the OSR, nor their use by organizing authorities, nor the inspection of a boat under the OSR in any way limits or reduces the complete and unlimited responsibility of the *person in charge*.
- ** 1.02.3 By participating in a race conducted under the OSR, the *person in charge*, each competitor and boat owner agrees to reasonably cooperate with the organizing authority and World Sailing in the development of an independent incident report as specified in OSR 2.02.
- ** 1.03 **Definitions, Abbreviations, Word Usage**
- ** 1.03.1 **Table 1 – Definitions of Terms used in this document**

Abbreviation	Description
#	Pound force (lbf)
ABS	American Bureau of Shipping
AIS	Automatic Identification Systems
Coaming	The part of the cockpit, including the transverse after limit, over which water would run when the boat is floating level and the cockpit is filled to overflowing
COLREGS	International Regulations for Preventing Collisions at Sea
Contained Cockpit	A cockpit where the combined area open aft to the sea is less than 50% maximum cockpit depth x maximum cockpit width
Crewmember	Every person on board
DSC	Digital Selective Calling
EN	European Norm
EPIRB	Emergency Position-Indicating Radio Beacon
ERS	World Sailing - Equipment Rules of Sailing
First Launch	Month & year of the first launching when the individual boat, was completed and equipped for sailing
GMDSS	Global Maritime Distress & Safety System
GNSS	Global Navigation Satellite System

SECTION 1 – FUNDAMENTAL AND DEFINITIONS

Categories

GPS	Global Positioning System
Hatch	The term hatch includes the entire hatch assembly including the lid or cover as part of that assembly
HMPE	High Modulus Polyethylene (Dyneema®/Spectra® or equivalent)
IBRD	International Beacon Registration Database
IMO	International Maritime Organization
ISAF	International Sailing Federation – (now World Sailing)
ISO	International Standard Organization or International Organization for Standardization
Jackstay	A <u>securely fastened</u> webbing or rope which permits a <u>crewmember</u> to move from one part of the boat to another without having to unclip a safety harness <u>tether</u>
L _H	Hull Length as defined by the ERS
Lifeline	Rope or wire line rigged as guardrail/guard line around the deck
LSA	<u>IMO</u> International Life-Saving Appliance Code
L _{WL}	(Length of) loaded waterline
Moveable Ballast	Material carried for the sole purpose of increasing weight and/or influencing stability and/or trim and which may be moved transversely but not varied in weight while a boat is racing
ORC	Offshore Racing Congress (formerly Offshore Racing Council)
OSR	Offshore Special Regulation(s)
Permanently Installed	The item is effectively built-in by e.g. bolting, welding, glassing etc. and may not be removed for or during racing
PLB	Personal Locator Beacon
Rode	Rope, chain, or a combination of both, which is used to connect an anchor to the boat
RRS	World Sailing – Racing Rules of Sailing
Securely Fastened	Held strongly in place by a method (e.g. rope lashings, wing nuts) which will safely retain the fastened object in severe conditions including a 180° capsize and allows for the item to be removed and replaced during racing
SOLAS	Safety of Life at Sea Convention
STCW	Standards of Training, Certification and Watchkeeping for Seafarers
SSS	The Safety and Stability Screening numeral
STIX	ISO 12217-2 Stability Index
Tether	A safety line used to connect a safety harness to a strong point or Jackstay
Variable Ballast	Water carried for the sole purpose of influencing stability and/or trim and which may be varied in weight and/or moved while a boat is racing.
World Sailing	formerly the International Sailing Federation or ISAF

1.03.2 The words “shall” and “must” are mandatory, and “should” and “may” are permissive.

SECTION 2 – APPLICATION & GENERAL REQUIREMENTS

Categories **	2.01 Categories of Events Organizing authorities shall select from one of the following categories and may modify the <u>OSR</u> to suit local conditions.
MoMu3	2.01.4 Category 3 Races across open water, most of which is relatively protected or close to shorelines.
**	2.02 Incident Reporting The organizing authority of a race will establish whether any incidents occurred, which if reported would likely be relevant to evolving the Offshore Special Regulations, the plan review process, or in increasing safety. The organizing authority will follow any guidelines issued by World Sailing concerning incident reporting.
**	2.03 Inspection A boat may be inspected at any time. If she fails to comply with the <u>OSR</u> her entry may be rejected, or she will be subject to protest.
**	2.04 General Requirements
**	2.04.1 All equipment required by OSR shall:
**	a) function properly,
**	b) be regularly checked, cleaned and serviced,
**	c) if it has an expiry date, it will not have exceeded its expiry date whilst racing,
**	d) when not in use be stowed in conditions in which deterioration is minimized,
**	e) be readily accessible, and
**	f) be of a type, size and capacity suitable and adequate for the intended use and size of the boat.
**	2.04.2 Heavy items shall be permanently installed or securely fastened.

SECTION 3 – STRUCTURAL FEATURES, STABILITY, FIXED EQUIPMENT

Categories		A boat shall be/have:
	3.01	Strength of Build and Rig
**	3.01.1	Properly rigged, fully seaworthy and shall meet the OSR.
**	3.01.2	Equipped with shrouds and at least one forestay that shall remain connected to the mast and the boat while racing (not applicable to boats with free-standing masts).
**	3.01.3	The forestay referenced above shall be sized and connected in a way that ensures it is capable of withstanding the full sailing loads independent of any headsail luff load capacity.
	3.02	Watertight and Structural Integrity of a Boat
**	3.02.1	Essentially watertight and all openings shall be capable of being immediately secured. Centre board or daggerboard trunks and the like shall not open into the interior of a hull except via a watertight maintenance hatch with the opening entirely above the waterline .
	3.05	Stability and Flotation – Multihulls
Mu0,1,2,3,4	3.05.1	Watertight bulkheads and compartments (which may include permanently installed flotation material) in each hull, to ensure that the boat is effectively unsinkable and capable of floating in a stable position with at least half the length of one hull flooded (see OSR 3.13.2).
Mu0,1,2,3,4	3.05.2	If first launched after 1998, a boat shall have transverse watertight bulkheads at intervals of not more than 4 m (13'-3") in every hull without accommodations.
Mu0,1,2,3,4	3.05.3	Designed and built to resist capsize.
	3.07	Exits, Escape Hatches, Underside Clipping Points and Handholds – Multihulls
	3.07.1	Exits
Mu0,1,2,3	a)	At least two exits in each hull which contains accommodations.
	3.07.2	Escape Hatches – General
Mu0,1,2,3,4	a)	If 12 m (39'-4") L_H and greater each hull which contains accommodation shall have:
Mu0,1,2,3,4	i	an escape hatch for access to and from the hull in the event of an inversion,
Mu0,1,2,3,4	ii	if first launched after 2002, a minimum clearance diameter through each escape hatch of 450 mm (18") or when an escape hatch is not circular, sufficient clearance to allow a crewmember to pass through fully clothed,
Mu0,1,2,3,4	iii	each escape hatch to be above the waterline when the boat is inverted,
Mu0,1,2,3,4	iv	if first launched after 2000, each escape hatch to be at or near the midships station.
Mu0,1,2,3,4	b)	Each escape hatch shall have been opened both from inside and outside within 6 months prior to the race.
	3.07.3	Escape Hatches – Catamarans
Mu0,1,2,3,4		If first launched after 2002, each escape hatch to be on the side nearest the vessel's central axis.
	3.07.4	Escape Hatches – Trimarans
Mu0,1,2,3,4	a)	If first launched after 2002 with L_H 12 m (39'-4") and greater, at least two escape hatches in compliance with the dimensions in OSR 3.07.2 a) ii,
	3.07.5	Underside Clipping Points and Handholds
Mu0,1,2,3,4		On the underside, appropriate handholds and clipping points of sufficient capacity to enable all crewmembers to hold on and/or clip on securely.
Mu0,1,2,3,4	a)	On a trimaran these shall be around the central hull.
Mu0,1,2,3,4	b)	On a catamaran first launched after 2002, with a central nacelle, these shall be around the central nacelle.
	3.07.6	Escape Hatch Alternatives
Mu2,3,4		If a boat has L_H less than 12 m (39'-4") it shall have escape hatches in compliance with OSR 3.07.2 a), 3.07.4 a) and 3.07.4 b) or:

SECTION 3 – STRUCTURAL FEATURES, STABILITY, FIXED EQUIPMENT

Mu2,3,4	A boat shall be/have:
Mu2,3,4	<ul style="list-style-type: none"> a) in each hull which contains accommodation, a station where an emergency hatch may be cut. The cutting line shall be clearly marked both inside and outside with an outline and the words "ESCAPE CUT HERE", and b) tools suitable for cutting the emergency hatch, ready for instant use, adjacent to the cutting site. Each tool shall be secured to the vessel by a lanyard.
**	<p>3.08 Hatches & Companionways</p> <p>3.08.1 Hatch covers forward of the maximum beam station shall not open toward the interior of the boat, except hatches in the side of a coach roof or ports having an area of less than 0.071 m² (110 in²).</p> <p>3.08.2 A hatch, including a hatch over a locker shall be:</p> <ul style="list-style-type: none"> a) permanently attached and capable of being firmly shut immediately and remaining firmly shut in a 180° capsize, <p>3.08.3 Hatches not conforming with OSR 3.08.1 and OSR 3.08.2 shall be clearly labelled and used in accordance with the following instruction "NOT TO BE OPENED AT SEA".</p> <p>3.08.4 Companionway hatches:</p> <ul style="list-style-type: none"> a) fitted with a strong securing arrangement which shall be operable from the exterior and interior even when the boat is inverted, b) blocking devices: <ul style="list-style-type: none"> i capable of being retained in position with the hatch open or shut, ii secured to the boat (e.g. by lanyard) for the duration of the race, and iii permit exit in the event of inversion. <p>3.08.7 If a multihull with a companionway hatch extending below the local sheer line a boat shall either:</p> <ul style="list-style-type: none"> a) have a minimum sill height of 300 mm (12") and be capable of being blocked off up to the level of the local sheer line whilst giving access to the interior with the blocking device(s) in place, or b) be in compliance with ISO 11812 to design category A.
Mu0,1,2,3,4	
Mu0,1,2,3,4	
Mu0,1,2,3	<p>3.09 Cockpits</p> <p>3.09.1 General</p> <ul style="list-style-type: none"> a) cockpits shall self-drain quickly by gravity at all angles of heel and are permanently incorporated as an integral part of the boat, b) a cockpit sole shall be at least 2% L_{WL} above the waterline (or in IMS boats with first launch before 2003, at least 2% L above the waterline), and c) a bow, lateral, central, or stern well is a cockpit for the purposes of OSR 3.09. <p>3.09.2 Cockpit Volume</p> <p>The maximum combined volume below lowest coamings of all contained cockpits shall be:</p> <ul style="list-style-type: none"> b) series date before April 1992: 9% (L_{WL} x maximum beam x freeboard abreast the cockpit), c) series date after March 1992 as above for the appropriate category except that "lowest coamings" shall not include any aft of the FA station (the transverse station at which the upper corner of the transom meets the sheer line) and no extension of a cockpit aft of the working deck shall be included in calculation of cockpit volume. <p>3.09.3 Cockpit Drains</p> <p>Cockpit drain cross section area of unobstructed openings (after allowance for screens if fitted) shall be at least that of:</p> <ul style="list-style-type: none"> a) if less than 8.5 m (28') L_H: 2 x 25 mm (1") diameter or equivalent, b) if 8.5 m (28') L_H or greater: 4 x 20 mm (3/4") diameter or equivalent.
MoMu2,3,4	
**	<p>3.10 Sea Cocks or Valves</p> <p>Permanently installed sea cocks or valves on all through-hull openings below the</p>

SECTION 3 – STRUCTURAL FEATURES, STABILITY, FIXED EQUIPMENT



Waterline for integral deck scuppers and instrument through-hulls.

SECTION 3 – STRUCTURAL FEATURES, STABILITY, FIXED EQUIPMENT

Categories	A boat shall be/have:
**	<p>3.11 Sheet Winches Sheet winches mounted in such a way that an operator is not required to be substantially below deck.</p>
**	<p>3.12 Mast Step The heel of a keel stepped mast securely fastened to the mast step or adjoining structure.</p>
Mo0Mu**	<p>3.13 Watertight Bulkheads 3.13.1 Either a watertight "crash" bulkhead within 15% of L_H from the bow and abaft the forward end of L_{WL}, or permanently installed closed-cell foam buoyancy effectively filling the forward 30% L_H of the hull.</p>
Mo0Mu**	<p>3.13.2 Any required watertight bulkhead to be strongly built to take a full head of water pressure without allowing any leakage into the adjacent compartment.</p>
**	<p>3.14 Pulpits, Stanchions, Lifelines <u>Recommended</u> 3.14.1 General</p>
**	<p>The perimeter of the deck surrounded by system of lifelines and pulpits as follows:</p>
**	<p>a) continuous lifelines fixed only at (or near) the bow and stern. However, a gate on each side of a boat is permitted. Except at its end fittings and at gates, the movement of a lifeline in a fore-and-aft direction shall not be constrained. Temporary sleeving shall not modify tension in the lifeline,</p>
**	<p>b) minimum heights of lifelines and pulpit rails above the working deck and vertical openings:</p>
**	<p>i upper: 600 mm (24"),</p>
**	<p>ii intermediate: 230 mm (9"),</p>
**	<p>iii vertical opening: no greater than 380 mm (15") except that on a boat with a series date before 1993 where it shall be no greater than 560 mm (22"),</p>
MoMu3,4	<p>iv a boat less than 8.5 m (28') L_H may use a single lifeline system with a height between 450 mm (18") and 560 mm (22").</p>
**	<p>c) lifelines permanently supported at intervals of not more than 2.2 m (7'-2 1/2") and not passing outboard of supporting stanchions,</p>
**	<p>d) pulpit and stanchion bases permanently installed with pulpits and stanchions mechanically retained in their bases,</p>
**	<p>e) if a boat's first launch date is after 2024, the outside of pulpit and stanchion base tubes no further inboard from the perimeter of the deck than 5% of boat beam or 150 mm (6"), whichever is greater, nor further outboard than the perimeter of the deck, where the perimeter of the deck is defined as the hull and deck intersection at an angle of not more than 15 degrees to the horizontal in a transverse plane when the yacht is upright,</p>
**	<p>f) stanchions straight and vertical except that:</p>
**	<p>i within the first 50 mm (2") from the deck, stanchions shall not be displaced horizontally from the point at which they emerge from the deck or stanchion base by more than 10 mm (3/8"),</p>
**	<p>ii stanchions may be angled to not more than 10° from vertical at any point above 50 mm (2") from the deck.</p>
**	<p>g) a bow pulpit may be open provided the opening between the pulpit and any part of the boat does not exceed 360 mm (14"),</p>

SECTION 3 – STRUCTURAL FEATURES, STABILITY, FIXED EQUIPMENT

Categories

A boat shall be/have:

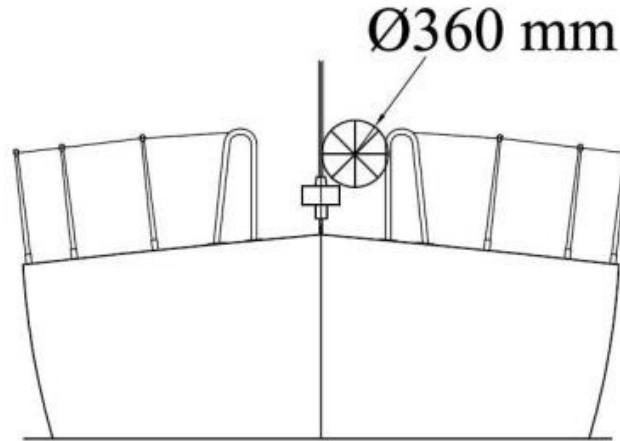

Figure 2 – Diagram Showing Pulpit Opening

- ** h) lifelines may terminate at or pass through adequately braced stanchions set inside and overlapping the bow pulpit,
- ** i) when a deflecting force of 4 kg (8.8 #) is applied to a lifeline at the mid-point of the longest span between supports that are aft of the mast, the deflection shall not exceed:
 - ** i) 50 mm (2") for an upper or single lifeline,
 - ** ii) 120 mm (4 3/4") for an intermediate lifeline.

3.14.2 Special Requirements for Pulpits, Stanchions, Lifelines on Multihulls

Mu0,1,2,3,4

When on a boat it is impractical to precisely follow OSR regarding pulpits, stanchions, lifelines, the regulations for monohulls shall be followed as closely as possible.

3.14.3 Lifeline Specifications

Mo4Mu**

Mo4Mu**

Mo4Mu**

**

**

**

**

Mo4Mu**

**

- b) lifelines of either:
 - i) stranded stainless steel wire, or
 - ii) HMPE,
- c) The minimum diameter is specified in table 4 below,
- d) Stainless steel lifelines shall be uncoated and used without close-fitting sleeving, however, temporary sleeving may be fitted provided it is regularly removed for inspection,
- e) A lanyard of synthetic rope may be used to secure lifelines provided the gap it closes does not exceed 100 mm (4"). This lanyard shall be replaced annually,
- f) All components of the lifeline enclosure system shall have a breaking strength no less than the lifeline,
- g) When HMPE is used, it shall be protected from chafe and spliced in accordance with the manufacturer's recommended procedures.

Table 4 – Lifeline Diameter Requirements

L _H	Wire Min. lifeline diameter	HMPE rope (Single braid) min. lifeline diameter	HMPE Core (Braid on braid) min. lifeline outside diameter
under 8.5 m (28')	3 mm (1/8")	4 mm (5/32")	6 mm (1/4")
8.5m – 13 m	4 mm (5/32")	5 mm (3/16")	7 mm (9/32")
over 13 m (42' 8")	5 mm (3/16")	5 mm (3/16")	7 mm (9/32")

SECTION 3 – STRUCTURAL FEATURES, STABILITY, FIXED EQUIPMENT

Categories	A boat shall be/have:
	3.15 Multihull Nets or Trampolines
	3.15.1 General
Mu0,1,2,3,4	The words "net" and "trampoline" are interchangeable. A net shall be:
Mu0,1,2,3,4	a) essentially horizontal,
Mu0,1,2,3,4	b) made from durable woven webbing, water permeable fabric, or mesh with openings not larger than 5 cm (2") in any dimension. Attachment points shall be planned to avoid chafe. The junction between a net and a boat shall present no risk of foot trapping,
Mu0,1,2,3,4	c) solidly fixed at regular intervals on transverse and longitudinal support lines and shall be fine stitched to a bolt rope, and
Mu0,1,2,3,4	d) able to carry the full weight of the crew either in normal working conditions at sea or in case of capsize when the boat is inverted.
	3.15.2 Trimarans with Double Crossbeams
Mu0,1,2,3,4	A trimaran with double crossbeams shall have nets on each side covering:
Mu0,1,2,3,4	a) the area formed by the crossbeams, central hull and outriggers,
Mu0,1,2,3,4	b) the triangles formed by the aft end of the central pulpit, the mid-point of each forward crossbeam, and the intersection of the crossbeam and the central hull,
Mu0,1,2,3,4	c) the triangles formed by the aftermost part of the cockpit or steering position (whichever is furthest aft), the mid-point of each after crossbeam, and the intersection of the crossbeam and the central hull, except that:
Mu0,1,2,3,4	d) OSR 3.15.2(c) is not a requirement when cockpit coamings and/or lifelines are present which comply with the minimum height requirements in OSR 3.14.
	3.15.3 Trimarans with Single Crossbeams
Mu0,1,2,3,4	A trimaran with a single crossbeam shall have nets between the central hull and each outrigger on each side between two straight lines from the intersection of the crossbeam and the outrigger, respectively to the aft end of the pulpit on the central hull, and to the aftermost point of the cockpit or steering position on the central hull (whichever is furthest aft).
	3.15.4 Catamarans
Mu0,1,2,3,4	A catamaran shall have nets covering the area defined laterally by the hulls and longitudinally by transverse stations through the forestay base and the aftermost point of the boom lying fore and aft. However, a catamaran with a central nacelle (non-immersed) may satisfy the regulations for a trimaran.
**	3.16 Spare
	3.18 Toilet
MoMu3,4	3.18.2 Securely installed toilet or fitted bucket.
	3.19 Bunks
MoMu1,2,3,4	3.19.1 Securely installed bunks.
	3.20 Cooking Facilities
MoMu0,1,2,3	Securely installed cooking stove, capable of being operated safely at sea, with fuel shutoff control.
	3.21 Drinking Water Tanks & Drinking Water
	3.21.1 Drinking Water Tanks
MoMu2,3	c) Securely installed delivery pump and water tank(s)), or reusable container(s) capable of providing sufficient amount of drinking water per person per day for the likely duration of the voyage.
	3.21.3 Emergency Drinking Water

SECTION 3 – STRUCTURAL FEATURES, STABILITY, FIXED EQUIPMENT

Categories
MoMu1,2,3

A boat shall be/have:

- a) at least 2 L (0.5 US Gal) per person of drinking water for emergency use in a dedicated and sealed container or container(s). **Recommended**

3.22 Hand Holds

**

Adequate hand holds fitted below deck.

SECTION 3 – STRUCTURAL FEATURES, STABILITY, FIXED EQUIPMENT

Categories	A boat shall be/have:	
	3.23 Bilge Pumps and Buckets	
** Mu0,1,2,3,4	3.23.1	a) two strong buckets, each with a lanyard and of at least 9 L (2.4 US Gal) capacity, e) provision to pump out all watertight compartments (except those filled with impermeable buoyancy).
**	3.23.2	All required permanently installed bilge pumps shall be operable with all cockpit seats, hatches and companionways shut and with permanently installed discharge pipe(s) of sufficient capacity.
**	3.23.3	Bilge pumps shall not be connected to cockpit drains and shall not discharge into a contained cockpit.
**	3.23.4	Bilge pumps shall be readily accessible for maintenance and for clearing out debris.
**	3.23.5	All removable bilge pump handles retained by a lanyard.
	3.24 Compass	
MoMu0,1,2,3		Marine magnetic compass capable of being used as a steering compass:
**	a)	Permanently installed marine magnetic steering compass, independent of any power supply, correctly adjusted with deviation card,
MoMu0,1,2,3	b)	a second compass which may be hand-held and/or electronic.
	3.25 Halyards	
**	3.25.1	A minimum of two halyards, each capable of hoisting a sail, on each mast.
MoMu0,1,2,3	3.25.2	No halyard shall be locked, lashed, or otherwise secured to the mast in a way that requires a person to go aloft to lower a sail in a controlled manner, except for a headsail in use with a furling device.
	3.27 Navigation Lights	
**	3.27.1	Shall carry navigation lights that meet Coast Guard/National Safety Authority of the Organizing Authority.
**	3.27.2	Mounted so that they will not be obscured by sails.
MoMu0,1,2,3	3.27.3	Reserve lights having the same specifications as above, and that can be powered independently.
**	3.27.4	Spare bulbs (not required for LED).
	3.28 Engines, Generators, Fuel	
	3.28.1 Propulsion Engines	A boat shall have a mechanical propulsion system that is ready for immediate use.
**	3.28.2 Generator	
MoMu0,1,2,3		If an optional generator separate from the propulsion engine is carried, it shall be installed in accordance with the manufacturer's guidelines.
	3.28.3 Liquid Fuel Systems	
Mu1,2,3	a)	all fuel tanks for storage of liquid fuels shall be rigid (but may have permanently installed flexible linings) and shall have a shutoff valve,
**		
**	b)	at the start a boat with a combustion engine shall carry sufficient fuel to meet charging requirements for the duration of the race and to motor at the above minimum speed for at least 5 hours.
**		
MoMu0,1,2,3		
MoMu0,1,2,3		

SECTION 3 – STRUCTURAL FEATURES, STABILITY, FIXED EQUIPMENT

Categories	A boat shall be/have:	
**	3.28.4 Battery Systems	a) batteries installed after 2011 shall be of the sealed type from which liquid electrolyte cannot escape, Recommended
**		b) At the start a boat with an electric engine shall carry sufficient capacity to meet electrical requirements for the duration of the race and to motor at the above minimum speed for at least 5 hours.
MoMu0,1,2,3		c) a dedicated engine/generator starting battery when an electric starter is the only method for starting the engine and/or separate generator,
	3.29 Communications Equipment, GPS, Radar, AIS	
Mo1,2,3	3.29.1	A hand-held marine VHF transceiver
**	3.29.4	A second radio receiver, which may be the handheld VHF in OSR 3.29.1 above, capable of receiving weather bulletins.
MoMu0,1,2,3	3.29.5	A marine radio transceiver with an emergency antenna when the regular antenna depends upon the mast.
MoMu0,1,2,3		Sail Canada prescribes that a boat shall have a VHF radio transceiver in accordance with 3.29.6.
MoMu0,1,2,3	3.29.6	If the marine radio transceiver is a VHF:
MoMu0,1,2,3		a) a minimum rated output power of 25 W,
MoMu1,2,3		b) if installed after 2015 be DSC capable,
MoMu3		e) a masthead antenna and co-axial feeder cable with not more than 40% power loss, Recommended
MoMu1,2,3		f) DSC capable VHF transceivers shall be programmed with an assigned MMSI (unique to the boat), be connected to a GPS receiver and be capable of making distress alert calls as well as sending and receiving a DSC position report with another DSC equipped station,
Mo0,1,2,3	3.29.7	An <u>AIS</u> Transponder which either: Recommended
Mu1,2,3		a) shares the masthead VHF antenna via a low loss AIS antenna splitter, or
MoMu0,1,2,3		b) has a dedicated AIS antenna not less than 38 cm (15”) in length mounted with its base not less than 3 m (10’) above the waterline and co-axial feeder cable with not more than 40% power loss.
MoMu0,1,2,3		
MoMu3	3.29.8	A <u>GPS</u> .

SECTION 4 – PORTABLE EQUIPMENT

Categories		A boat shall have:
	4.01	Sail Letters & Numbers
**	4.01.1	Identification on sails which complies with RRS 77 and RRS Appendix G.
MoMu0,1,2,3	4.01.2	An alternative means of displaying identification as required under RRS Appendix G for a mainsail, to be displayed when none of the numbered sails are set. Recommended
	4.02	Search and Rescue Visibility
Mu0,1,2,3,4	4.02.3	A 1 m ² (11 ft ²) area of highly visible pink, orange or yellow showing when the boat is inverted.
	4.03	Soft Wood Plugs
**		A tapered soft wood plug stowed adjacent to every through-hull opening.
	4.04	Jackstays and Clipping Points
MoMu0,1,2,3	4.04.1	Permanently Installed fittings for jackstay ends and clipping points.
MoMu0,1,2,3	4.04.2	Jackstays which shall:
MoMu0,1,2,3		a) be independent on each side of the deck,
MoMu0,1,2,3		b) enable a crewmember to move readily between the working areas on deck and the cockpit(s) with the minimum of clipping and unclipping operations,
MoMu0,1,2,3		c) have a breaking strength of 2040 kg (4500#) and be uncoated and non-sleeved stainless steel 1 x 19 wire of minimum diameter 5 mm (3/16"), webbing or HMPE rope.
MoMu0,1,2,3	4.04.3	Clipping points which shall:
MoMu0,1,2,3		a) be adjacent to stations such as the helm, sheet winches and masts, where crewmembers work,
MoMu0,1,2,3		b) enable a crewmember to clip on before coming on deck and unclip after going below,
MoMu0,1,2,3		c) enable two-thirds of the crew to be simultaneously clipped on without depending on jackstays,
Mu0,1,2,3		d) on a trimaran with a rudder on the outrigger, permit a crewmember to repair the steering mechanism whilst attached to a clipping point.
	4.05	Fire Fighting Equipment
**	4.05.1	A fire blanket adjacent to every cooking device. Recommended
MoMu1,2,3	4.05.2	Fire Extinguishers that meet Coast Guard/National Safety Authority of the Organizing Authority requirements for the size of boat.
	4.06	Anchors
MoMu1,2,3	4.06.1	1 un-modified anchor that meet the anchor manufacturer's recommendation based on the boat's dimensions with suitable combination of chain and rope, ready for immediate assembly, and ready for deployment within 5 minutes except that for a boat less than 8.5 m (28') L _H .
	4.07	Flashlights and Searchlights
Mo0,1,2,3		Watertight lights (minimum IP67 rated) with spare batteries and bulbs as follows, or a watertight (minimum IP67 rated) rechargeable LED torch, of at least 400 Lumens.
Mu**		
MoMu0,1,2,3		a) a searchlight, suitable for searching for a person overboard at night and for collision avoidance,
Mo0,1,2,3		b) stowed in each grab bag (see OSR 4.21), a flashlight in addition to OSR 4.07 a). Recommended
Mu**		
Mo0,1,2,3		c) the flashlight in OSR 4.07 b) shall be stowed in the grab bag (see OSR 4.21). Recommended
Mu**		
	4.08	First Aid Manual and First Aid Kit
**		A First Aid Manual and First Aid Kit. The contents and storage of the First Aid Kit shall reflect the likely conditions and duration of the passage, and the number of <i>crewmembers</i> .
	4.09	Foghorn
**		A foghorn.

Categories		A boat shall have:
**	4.10 Radar Reflector	
**	4.10.1	A passive radar reflector with:
**		a) octahedral circular plates of minimum diameter 30 cm (12”),
**		b) octahedral rectangular plates of minimum diagonal dimension 40 cm (16”), or
**		c) A tubular radar reflector is acceptable if permanently mounted within 15 degrees of vertical.
MoMu0,1,2,3	4.11 Navigation Equipment	
	4.11.1	Navigational charts and chart plotting equipment.
**	4.12 Safety Equipment Location Chart	
		A safety equipment location diagram in durable waterproof material, clearly displayed in the main accommodation, marked with the location of principal items of safety equipment.
MoMu0,1,2,3	4.13 Depth, Speed and Distance Instruments	
MoMu1,2,3,4	4.13.1	A knot meter or distance measuring instrument (log).
	4.13.2	A depth sounder.
	4.14	Spare Number
MoMu0,1,2,3	4.15 Emergency Steering	
MoMu0,1,2,3	4.15.1	An emergency tiller capable of being fitted to the rudder stock except when:
MoMu0,1,2,3		a) the principal method of steering is by means of an unbreakable metal tiller,
MoMu0,1,2,3		b) there are two methods (e.g. tillers, wheels) of controlling a rudder, neither of which shares components with the other except for the rudder stock.
MoMu0,1,2,3	4.15.2	A proven method of emergency steering with the rudder disabled.
**	4.16 Tools and Spare Parts	
**	4.16.1	Tools and spare parts, suitable for the duration and nature of the passage.
**	4.16.2	An effective means to quickly disconnect or sever the standing rigging from the boat.
**	4.17 Boat’s Name	
**		The boat’s name on miscellaneous buoyant equipment, such as lifejackets, cushions, lifebuoys, recovery slings, grab bags, etc.
**	4.18 Retro-Reflective Material	
**		Marine grade retro-reflective material on lifebuoys, recovery slings, life rafts and lifejackets.
Mo0,1,2,3	4.21 Grab Bags Recommended	
Mu**	4.21.1	A grab bag shall have inherent flotation, at least 0.1 m ² (1 ft ²) area of highly visible color (e.g. dayglo yellow or orange) on the outside, shall be marked with the name of the boat, and shall have a lanyard and clip. If a grab bag has to accompany a specific life raft, it shall be clearly marked with the identity of its corresponding raft.
Mu3,4	4.21.4	The following shall be either stowed with a life raft, or in a watertight compartment or a grab bag. The container shall be readily accessible whether or not the boat is inverted:
Mo3Mu3,4		a) 3 hand flares,
Mo3Mu3,4		b) watertight strobe light with spare batteries (may be part of the flashlight),
Mo3Mu3,4		c) knife, and
Mo3Mu3,4		d) whistle.
MoMu1,2,3	4.22 Crew Overboard Identification and Recovery	
	4.22.2	a) For boats with only two crew members, a GPS capable of recording a crew overboard position, within 10 seconds, and monitoring that position without having to go below deck.
MoMu3,4	4.22.3 Lifebuoys	
**		a) a lifebuoy with a self-igniting light, a whistle, and a drogue within reach of the helmsman and ready for immediate use,
**		e) each inflatable lifebuoy and any automatic device shall be tested and serviced at intervals in accordance with its manufacturer’s instructions.

Categories		A boat shall have:
**	4.22.4 Heaving Line	A heaving line, no less than 6 mm (1/4") diameter, 15–25 m (50–75') long, readily accessible to cockpit.
MoMu0,1,2,3	4.22.5 Recovery Sling	A recovery sling which includes a:
MoMu0,1,2,3		a) buoyant line of length no less than the shorter of 4 times L_H or 36m (120'),
MoMu0,1,2,3		b) buoyancy section (horseshoe) with no less than 90 N (20#) buoyancy,
MoMu0,1,2,3		c) minimum strength capable to hoist a crewmember aboard.
**	4.23 Pyrotechnic and Light Signals	A boat shall carry the number and type of flares required by its National Safety Authority for day and night requirements at a minimum. They shall not be older than 4 years.
**		
MoMu0,1,2,3	4.24	Spare Number
**	4.25 Cockpit Knife	A strong, sharp knife, in a securely restrained sheath shall be readily accessible from the deck or a cockpit.
**	4.26 Storm & Heavy Weather Sail Inventory Recommended	the following storm & heavy weather sails as specified in OSR 4.27:
MoMu3	4.26.1	either a storm trysail or mainsail reefing to reduce the luff by at least 40% (or rotating wing mast if suitable),
MoMu0,1,2,3	4.26.2	heavy weather jib, Recommended
	4.27 Storm & Heavy Weather Sail Specifications Recommended	Where required by OSR 4.26, the specifications of heavy weather sails shall follow:

Categories

A boat shall have:

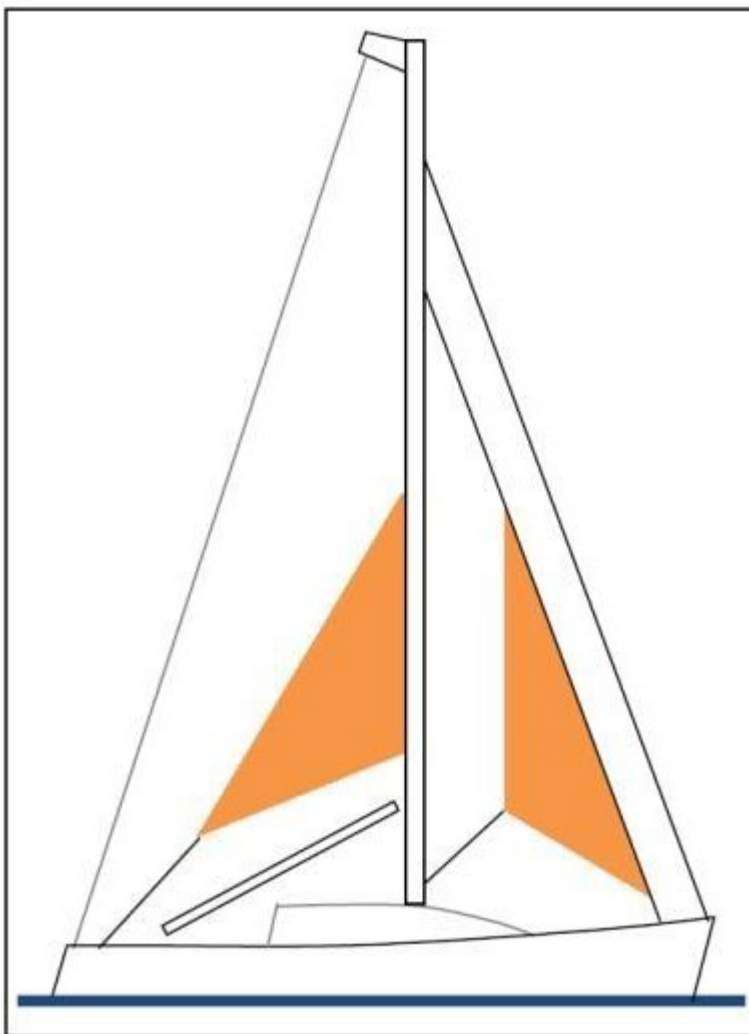
**Figure 3 – Storm Sails****4.27.1 Design Recommended**

- ** a) the material of the body of a storm sail purchased after 2013 shall have a highly visible color (e.g. dayglo pink, orange or yellow),
- ** b) aromatic polyamides, carbon and similar fibers shall not be used in a trysail or storm jib, but HMPE and similar materials are permitted,
- ** c) sheeting positions on deck for each storm and heavy-weather sail,
- ** d) sheeting positions for the trysail independent of the boom, and
- ** e) the maximum area of storm and heavy weather sails shall be lesser of the areas below or as specified by the boat designer or sailmaker.

4.27.2 A Storm Trysail with: Recommended

- MoMu0,1,2,3 a) area not greater than 17.5% mainsail hoist (P) x mainsail foot length (E),
- MoMu0,1,2,3 b) for sails made after 2011: The storm trysail area calculated as $(0.5 \times \text{leech length} \times \text{shortest distance between tack point and leech})$,
- MoMu0,1,2,3 c) no headboard,
- MoMu0,1,2,3 d) no battens,
- MoMu0,1,2,3 e) sail number and letters on both sides, as large as practicable, and
- MoMu1,2,3 f) in the case of a boat with an in-mast furling mainsail, the storm trysail shall be capable of being set while the mainsail is furled.

4.27.3 A Heavy Weather Jib (or Heavy Weather Sail in a Boat with no Forestay) Recommended

**

a) area, in unreefed condition, of 13.5% height of the **foretriangle** squared, and

Categories

**

A boat shall have:

**

b) readily available method, independent of a luff groove, to attach to the stay.
For sails made after 2011: Storm and heavy weather jib areas calculated as: $(0.255 \times \text{luff length} \times (\text{luff perpendicular} + 2 \times \text{half width}))$.

SECTION 5 – PERSONAL EQUIPMENT

Categories		Each crewmember shall have:
	5.01	Lifejacket
**	5.01.1	A lifejacket which shall:
**		a) i if manufactured before 2012 comply with ISO 12402-3 (Level 150) or equivalent, including EN_396 or UL 1180 and:
**		• if inflatable have a gas inflation system
**		• have crotch/thigh straps (ride up prevention system)
**		ii if manufactured after 2011 comply with ISO 12402-3 (Level 150) and be fitted with a whistle, lifting loop, reflective material automatic/manual gas inflation system:
**		• crotch/thigh straps (ride up prevention system)
**		or
**		iii if manufactured after 2011 comply with UL 1180 and be fitted with a whistle, reflective material and:
**		• crotch/thigh straps (ride up prevention system)
**		• an integral safety harness in compliance with OSR 5.02
MoMu0,1,2,3		Sail Canada note - ISO 12402 is not currently approved by Transport Canada.
**		b) have an emergency position indicating light in accordance with either ISO 12402-8 or LSA code 2.2.3,
MoMu0,1,2,3		c) be clearly marked with the boat's or wearer's name,
**		d) have a sprayhood in accordance with ISO 12402-8,
MoMu0,1,2,3		f) if inflatable, be regularly checked for air retention.
**	5.01.2	A boat shall carry at least one gas inflatable lifejacket spare cylinder and, if appropriate, spare activation head for each type of lifejacket on board.
**	5.01.4	The <i>person in charge</i> shall personally check each lifejacket at least once annually.
	5.02	Safety Harness and Tethers
MoMu0,1,2,3	5.02.1	A harness that complies with ISO 12401 or equivalent.
MoMu0,1,2,3	5.02.2	A tether that shall:
MoMu0,1,2,3		a) comply with ISO 12401 or equivalent,
MoMu0,1,2,3		b) not exceed 2 m (6'-6") including the length of the hooks,
MoMu0,1,2,3		c) have self-closing hooks,
MoMu0,1,2,3		d) have overload indicator flag embedded in the stitching, and
MoMu0,1,2,3		e) be manufactured after 2000.
MoMu0,1,2,3	5.02.3	either:
MoMu0,1,2,3		a) a tether not exceeding 1 m (3'-3") including the length of the hooks Recommended , or
MoMu0,1,2,3		b) an intermediate self-closing hook on a 2 m (6'-6") tether. Recommended
MoMu0,1,2,3	5.02.5	A tether which has been overloaded shall be replaced.

Categories	6.01 Training Recommended
MoMu3	6.01.2 Sail Canada prescribes that at least 30% but not fewer than two crewmembers, including the Person in Charge, shall have undertaken a Sail Canada accredited Coastal Personal Survival Training course, or training accepted as equivalent by the <i>Organizing Authority</i>, within the five years before the start of the race. This training meets the requirement of OSR 6.01.3 below.
MoMu3	6.01.3 When there are only two crew members, at least one shall have undertaken training within the five years before the start of the race in OSR 6.02 Training Topics.
	6.02 Training Topics
MoMu0,1,2,3	6.02.1 Giving Assistance to Other Craft
MoMu0,1,2,3	6.02.2 Personal Safety Gear, theory and practice
MoMu0,1,2,3	6.02.3 Care and Maintenance of Safety Gear
MoMu0,1,2,3	6.02.4 Fire Precautions and Firefighting, theory and practical
MoMu0,1,2,3	6.02.5 Crew Overboard Prevention and Recovery
MoMu0,1,2,3	6.02.6 Hypothermia, Cold Shock and Drowning
MoMu0,1,2,3	6.02.7 Crew Health
MoMu0,1,2,3	6.02.8 Marine Weather
MoMu0,1,2,3	6.02.9 Heavy Weather
MoMu0,1,2,3	6.02.10 Storm Sails
MoMu0,1,2,3	6.02.11 Damage Control
MoMu0,1,2,3	6.02.12 Search and Rescue Organization
MoMu0,1,2,3	6.02.13 Pyrotechnics and Signaling Gear, theory and practical
MoMu0,1,2,3	6.02.14 Emergency Communications, theory and practical
MoMu0,1,2,3	6.02.15 Life rafts and Abandon Ship, theory and practical
	6.03 Spare Number
	6.04 Routine Training On-Board Recommended
**	At least annually the crews shall practice the drills for:
**	a) crew-overboard recovery, and
**	b) abandonment of vessel.
	6.05 Medical Training Recommended
MoMu3,4	6.05.3 At least two crew members shall be familiar with First Aid procedures, hypothermia, drowning, cardio-pulmonary resuscitation, and relevant communications systems.